

Galileo 500 optyka

50W | 230V/12V | QR-CB51 | GU5,3



500.001.0.00.01.050

Dane produktu: Product data:

Materiał: aluminium **Material:** aluminum

Dostępne kolory: Available colors:

- satyna satin
- czarny mat / czarny połysk black mat / black gloss
- biały mat / biały połysk white mat / white gloss

Kąt obrotu: poziom 359° pion 190°

Angle of rotation: horizontal 359° / vertical 190°

Montaż: adapter (A) / nastropowo (B) / wstropowo (C)

Montage: adapter (A) / ceiling-mounted (B) / recessed (C)

Zasilanie: 230V/12V **Power supply:** 230V/12V

Źródło światła: QR-CB51(50W)

Lightsource: QR-CB51(50W)

Rodzaj trzonka: GU5,3 **Kind of spot:** GU5,3

IP: 20 **IP:** 20

Waga: 0,7 kg **weight:** 0,7 kg

Przykładowe gobo: Sample gobo:

Sample gobo:

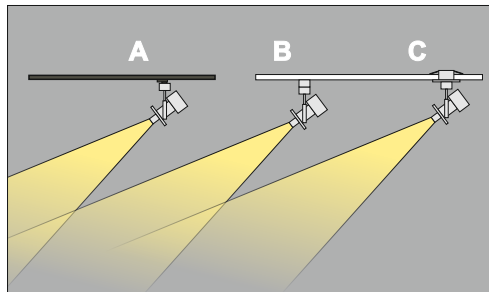
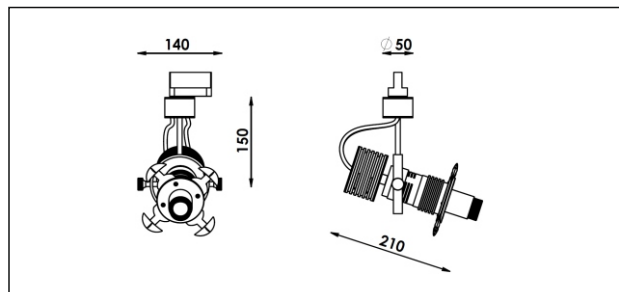
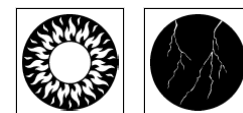

Aksesoria (opcjonalnie)

Accessories (optional):

- gobo gobo
- filtry dichroiczne dichroic filters

Sposoby montażu: ways of mounting:

- A. do szynprzewodu (adapter)** into track lines (adapter)
- B. bezpośrednio do podłoża (nastropowo)** directly into the ground (ceiling-mounted)
- C. wstropowo** recessed

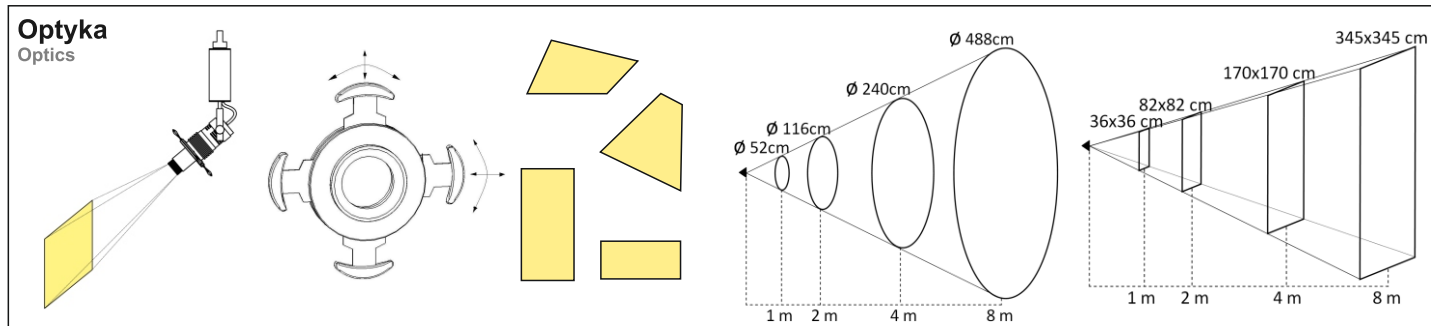

Nr			W	V	kg	mm	
500.001.0.00.01.050	adapter	QR-CB51 [GU5,3]	50W	230V/12V	0,7kg	140/210/50	satyna
500.011.0.00.01.050	nastropowa	QR-CB51 [GU5,3]	50W	230V/12V	0,7kg	140/210/50	satyna
500.021.0.00.01.050	wstropowa	QR-CB51 [GU5,3]	50W	230V/12V	0,7kg	140/210/50	satyna
500.001.0.01.01.050	adapter	QR-CB51 [GU5,3]	50W	230V/12V	0,7kg	140/210/50	czarny mat
500.011.0.01.01.050	nastropowa	QR-CB51 [GU5,3]	50W	230V/12V	0,7kg	140/210/50	czarny mat
500.021.0.01.01.050	wstropowa	QR-CB51 [GU5,3]	50W	230V/12V	0,7kg	140/210/50	czarny mat
500.001.0.02.01.050	adapter	QR-CB51 [GU5,3]	50W	230V/12V	0,7kg	140/210/50	czarny połysk
500.011.0.02.01.050	nastropowa	QR-CB51 [GU5,3]	50W	230V/12V	0,7kg	140/210/50	czarny połysk
500.021.0.02.01.050	wstropowa	QR-CB51 [GU5,3]	50W	230V/12V	0,7kg	140/210/50	czarny połysk
500.001.0.03.01.050	adapter	QR-CB51 [GU5,3]	50W	230V/12V	0,7kg	140/210/50	biały mat
500.011.0.03.01.050	nastropowa	QR-CB51 [GU5,3]	50W	230V/12V	0,7kg	140/210/50	biały mat
500.021.0.03.01.050	wstropowa	QR-CB51 [GU5,3]	50W	230V/12V	0,7kg	140/210/50	biały mat
500.001.0.04.01.050	adapter	QR-CB51 [GU5,3]	50W	230V/12V	0,7kg	140/210/50	biały połysk
500.011.0.04.01.050	nastropowa	QR-CB51 [GU5,3]	50W	230V/12V	0,7kg	140/210/50	biały połysk
500.021.0.04.01.050	wstropowa	QR-CB51 [GU5,3]	50W	230V/12V	0,7kg	140/210/50	biały połysk

* Dedykowane żarówki BLV Reflekto czarna lub srebrna
* Dedicated lamp BLV Reflekto black or silver