

813.030.1.00.03.050

Leonardo 813 W

3x50W | 230V/12V | QR111 | G53 |
3x100W | 230V | QPAR111 | GZ10 |



Dane produktu: Product data:

Materiał: aluminium Material: aluminum

Dostępne kolory: Available colors:

- **satyna** satin

Montaż: nastropowo (zwieszana) Montage: ceiling-mounted (hanging)

Zasilanie: 230V/12 lub 230V Power supply: 230V/12 or 230V

Źródło światła: Lightsource:

- **QR111 (3x50W)** QR111 (3x50W)
- **QPAR111 (3x100W)** QPAR111 (3x100W)

Rodzaj trzonka: G53 / GZ10 Kind of spot: G53 / GZ10

IP: 20 IP: 20

Waga: 2 kg weight: 2 kg

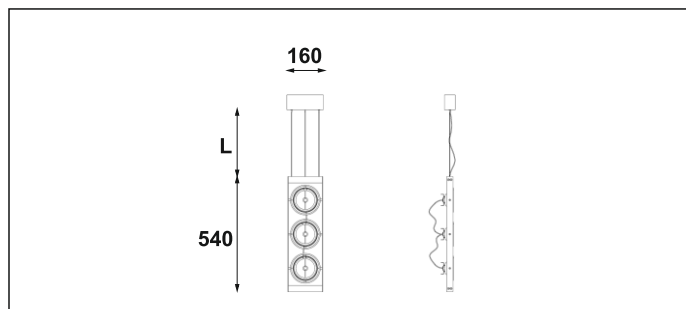

Długość linki (L):
The length of the rope (L):
maksymalnie 2500mm*

up to 2500mm *

*możliwa dowolna długość na zamówienie

*can be any length to order

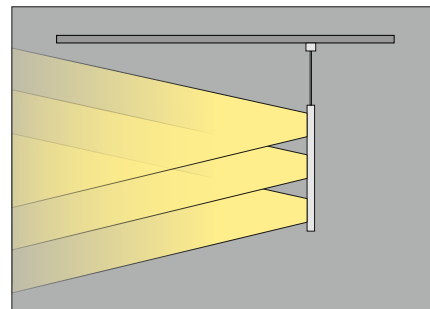

Nr			W	V	kg		
813.030.1.00.03.050 813.130.1.00.03.100	nastropowa nastropowa	QR111 [G53] QPAR111 [GZ10]	3x50W 3x100W	230V/12V 230V	2,0 kg 2,0 kg	540x160 540x160	satyna satyna