

814.030.1.00.04.050

## Leonardo 814 W

4x50W | 230V/12V | QR111 | G53 |  
4x100W | 230V | QPAR111 | GZ10 |



### Dane produktu: Product data:

**Materiał:** aluminium Material: aluminum

**Dostępne kolory:** Available colors:

- **satyna** satin

**Montaż:** nastropowo (zwieszana) Montage: ceiling-mounted (hanging)

**Zasilanie:** 230V/12 lub 230V Power supply: 230V/12 or 230V

**Źródło światła:** Lightsource:

- **QR111 (4x50W)** QR111 (4x50W)
- **QPAR111 (4x100W)** QPAR111 (4x100W)

**Rodzaj trzonka:** G53 / GZ10 Kind of spot: G53 / GZ10

**IP:** 20 IP: 20

**Waga:** 2,5 kg weight: 2,5 kg

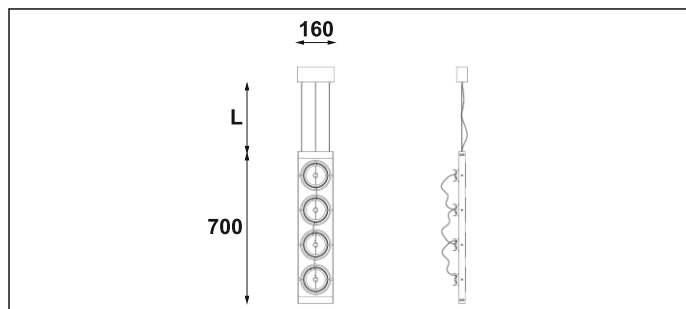

### Długość linki (L):

The length of the rope (L):

**maksymalnie 2500mm\***

up to 2500mm \*

\*możliwa dowolna długość na zamówienie

\*can be any length to order

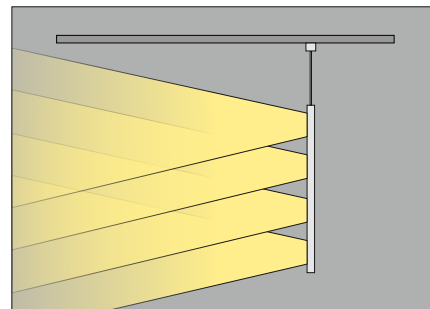

Nr			W	V	kg		
814.030.1.00.04.050 814.130.1.00.04.100	nastropowa nastropowa	QR111 [G53] QPAR111 [GZ10]	4x50W 4x100W	230V/12V 230V	2,5 kg 2,5 kg	700x160 700x160	satyna satyna